

### Features

ISSUE 2

February 1998

- Transformerless 2-wire to 4-wire conversion
- Battery and ringing feed to line
- Off-hook and dial pulse detection.
- Ring ground over-current protection
- Adjustable constant current feed.
- Relay driver
- Power Denial
- Wide Operating Range

**Ordering Information**

MH88612BV-2    20 Pin SIL Package

**0°C to 70°C**

### Applications

Line interface for:

- PABX
- Intercoms
- Key Telephone Systems
- Control Systems

### Description

The SLIC provides a complete interface between a switching system and a subscriber loop. Functions provided include battery feed and ringing feed to the subscriber line, 2-Wire to 4-Wire hybrid interfacing, constant current feed and dial pulse detection. The device is fabricated using thick film hybrid technology in a 20-pin single in-line package.

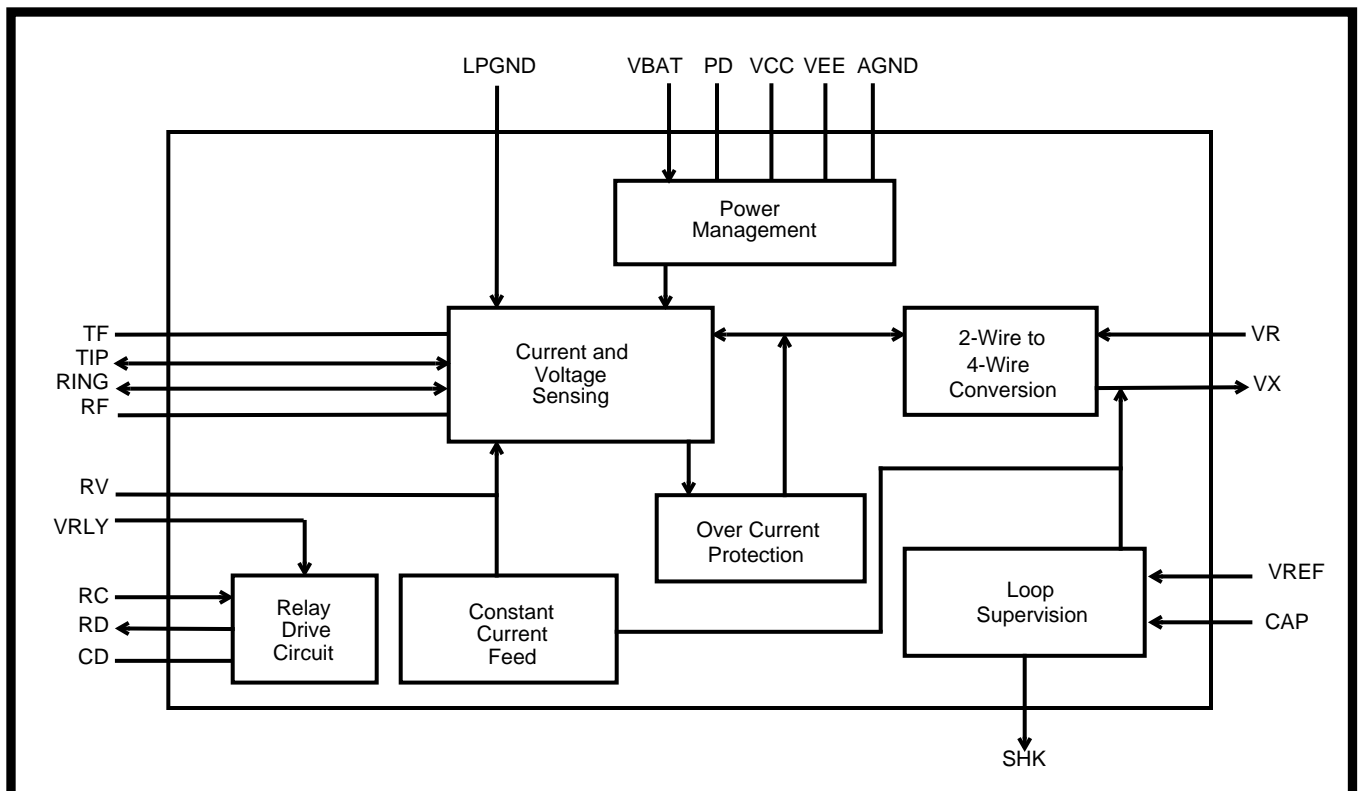

Figure 1 - Block Diagram

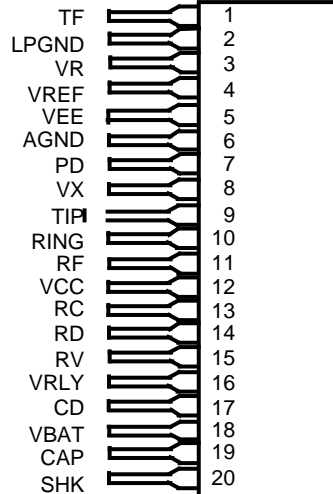

Figure 2 - Pin Connections

## Pin Description

Pin #	Name	Description
1	TF	<b>Tip Feed.</b> Connects to external diode for protection
2	LPGND	<b>Loop Ground.</b> Is the system ground reference with respect to $V_{BAT}$ . Normally connected to AGND.
3	VR	<b>Voice Receive (input)</b> is the 4 wire analog signal to the device.
4	VREF	<b>Voltage Reference (Input)</b> Constant current feed can be adjusted by the input voltage on $V_{REF}$ . This pin can also be grounded for normal 25mA loop current.
5	VEE	<b>Negative Power Supply Voltage (-5V).</b>
6	AGND	<b>Analog Ground (0V).</b>
7	PD	<b>Power Denial (Input).</b> A logic high will isolate the battery voltage to Tip/Ring.
8	VX	<b>Voice Transmit (Output)</b> is the 4-wire analog signal from the device.
9	TIP	Connects to the "Tip" lead of the telephone line.
10	RING	Connects to the "Ring" lead of the telephone line.
11	RF	<b>Ring Feed (Input)</b> is normally connected to Ring relay for negative battery feed voltage and ringing voltage input.
12	VCC	<b>Positive Power Supply Voltage (+5V).</b>
13	RC	<b>Relay Control (Input).</b> Active high.
14	RD	Open collector sinks current when RC is at logic high.
15	RV	<b>Ring Feed Voltage</b> connects to pin 11 (RF) through a normally closed relay.
16	VRLY	<b>Relay voltage Supply (+5V).</b>
17	CD	<b>Clamping Diode.</b> Connects to AGND
18	VBAT	<b>Negative Battery Feed Supply Voltage (-48V).</b>
19	CAP	Connects external capacitor to ground for ring trip.
20	SHK	<b>Switch Hook Detect (Output).</b> Active high.

## Functional Description

The SLIC performs a transformerless 2-wire to 4-wire conversion of the analog signal. The 2-wire circuit is the balanced line going to the subscriber loop, while the 4-wire circuit is the audio signal going to and from devices such as the voice codec or switching circuit. The SLIC also provides a switch hook (SHK) status output which goes high when the telephone is set off-hook.

## Constant Current Feed

The SLIC employs a complex feedback circuit to supply a constant feed current to the line. This is done by sensing the sum of the voltages across the internal feed resistors and comparing it to an input reference voltage ( $V_{REF}$ ) that determines the constant feed current. If  $V_{REF}$  (pin 4) is externally grounded, the constant current is set at 25mA. For a constant current setting between 18mA and 30mA,  $V_{REF}$  can be set between 8.75 Vdc and -6.35 Vdc. The relationship is defined by the equation:

$$I_{LOOP} = \frac{V_{BAT} - V_{REF}}{1.89} \text{ mA } (\pm 2 \text{ mA})$$

## Switch Hook Detection

When the DC current exceeds an internal threshold level, the switch hook (SHK) will go high. If the loop resistance is so high that  $V_{BAT}$  can no longer supply the required amount of loop current as determined by constant current supply circuit, the output of the switch hook (SHK) will go low to indicate that the loop resistance is too high and the line is on hook.

## Ringling And Ring Trip Detection

In Figure 3 a ringling signal (eg. 90 Vrms and -48Vdc) is applied to the line by disconnecting pin 15 (RV) from pin 11(RF), and connecting the ringling voltage at pin 11 (RF) by use of the relay K1.

The SLIC can detect an off-hook condition during ringling but there is a large AC component which must be filtered out to give a true off-hook condition at SHK.

A 1.0 $\mu$ F capacitor connected from pin 19 (CAP) to ground will provide adequate attenuation when ringling is applied. Once an off-hook condition has been detected a logic low should be applied to pin 13 (RC) which will deactivate the relay (K1) to disconnect the ringling voltage from pin 11 and

reconnect to pin 15. At that time the SLIC will revert to constant current feed operation.

For applications requiring Dial Pulse Detection the Capacitor connection to ground should be controlled such that the capacitor is only connected during ringling.

During off-hook conditions (closed loop), the capacitor should be switched out. This can be performed using a transistor, relay or system drive output of a codec. Applying AGND to the Ring Trip Filter Control pin as shown in Figure 4 will switch in the filter, whilst removing AGND, (with the switch in a tri-state condition), will switch out the filter.

For applications using DTMF signalling, the capacitor can be permanently connected to ground.

## Current Limit

The Tip or Ring of the telephone line may accidentally be shorted to ground. In such a case, current will only flow through the feed resistor. This high current will be sensed and reduced by the current limit circuit to a lower value to protect the internal circuitry.

## Power Denial

The power denial function is a feature of the MH88612B which allows for powering down of the subscriber loop. A logic high voltage applied to the power denial input effectively removes the battery voltage from the loop driver circuitry. The resulting  $I_{LOOP}$  is negligible and power consumption is minimized. The power denial function is useful for disabling a loop which may have a ground fault.

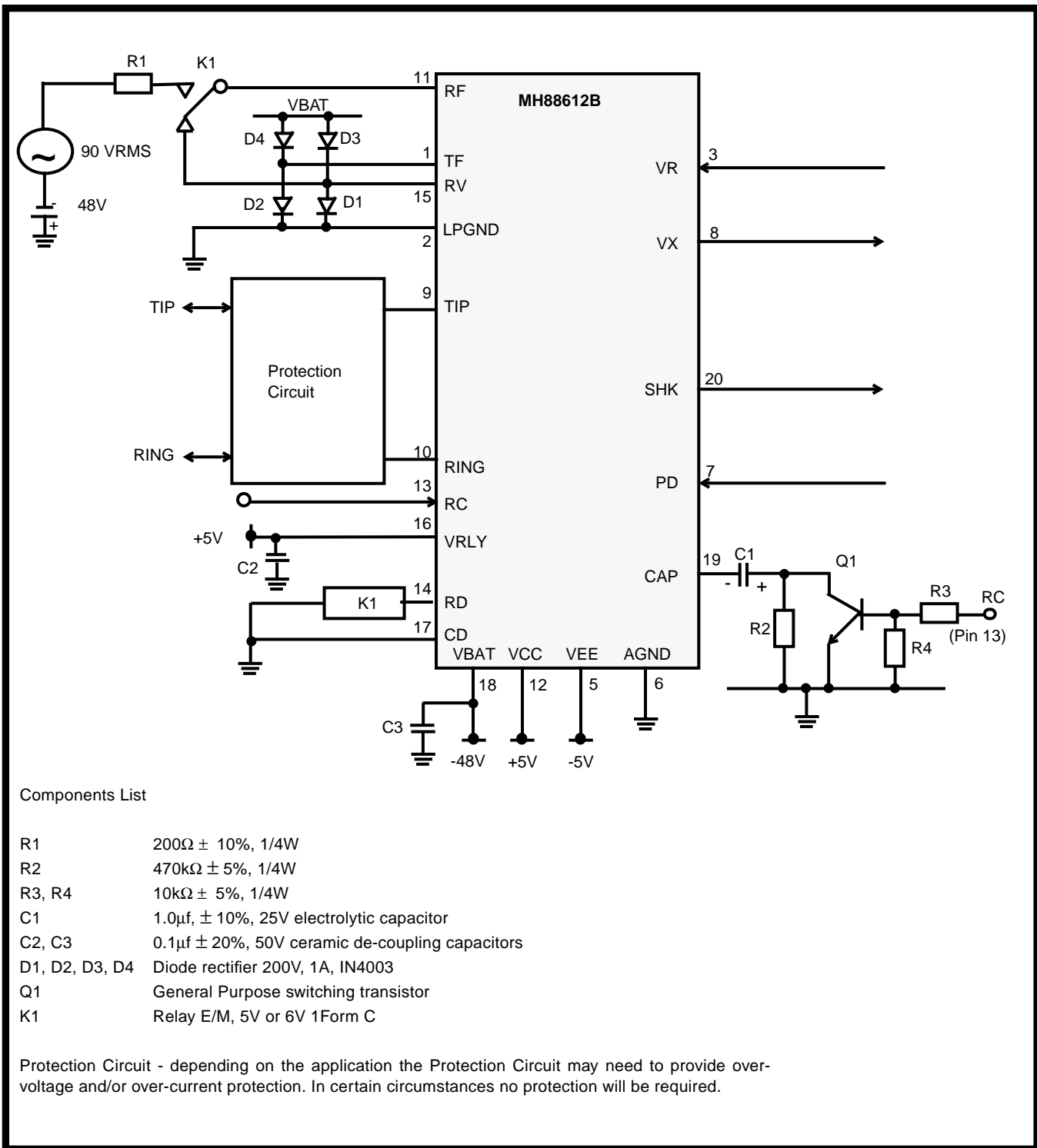

Figure 3 - Application Circuit

**Absolute Maximum Ratings\***

	Parameter	Symbol	Min	Max	Units
1	DC Supply Voltage LPGND = AGND	$V_{CC}$	-0.3	+15	V
		$V_{EE}$	-15	+0.3	V
		$V_{BAT}$	-80	+0.3	V
		$V_{RLY}$	-0.3	+40	V
		$V_{REF}$	-60	+15	V
2	Storage Temperature	$T_S$	-40	100	°C
3	Package Power Dissipation	PD		2	W

\*Exceeding these values may cause permanent damage. Functional operation under these conditions is not implied.

**Recommended Operating Conditions**

	Characteristics	Sym	Min	Typ <sup>‡</sup>	Max	Units	Test Conditions
1	Operating Supply Voltage	$V_{CC}$	4.75	5.0	5.25	V	Adjustable
		$V_{EE}$	-5.25	-5.0	-4.75	V	
		$V_{REF}$		0		V	
		$V_{BAT}$	-60	-48	-27	V	
		$V_{RLY}$		5		V	
2	Storage Temperature	$T_S$	-40	100	°C	2	Storage Temperature
3		$T_O$	0		70	°C	

‡ Typical figures are at 25°C with nominal supply voltages and are for design aid only

**DC Electrical Characteristics<sup>†</sup>** - Voltages are with respect to GNDA unless otherwise stated.

	Characteristics	Sym	Min	Typ <sup>‡</sup>	Max	Units	Test Conditions
1	Supply Current	$V_{CC}$	$I_{CC}$		6.6		mA
		$V_{EE}$	$I_{EE}$		-3.8		mA
		$V_{BAT}$	$I_{BAT}$		150	500	μA
					2		mA
2	Power Consumption	$P_C$		160		mW	Standby $V_{BAT} = -48V$
				1600		mW	Active (Off Hook)
3	Constant Current Line Feed	$I_{Loop}$	23	25	27	mA	$V_{REF} = AGND, V_{BAT} = -48V$
4	Adjustable Loop Current Range	$I_{Loop}$	18		30	mA	Adjustable with Ext. $V_{REF}$ input, $V_{BAT} = -48V$
5	Operating Loop Resistance	$R_{Loop}$			1200	Ω	$V_{BAT} = -48V @ I_{LOOP} = 18mA, R_{LOOP}$ includes telephone set
6	Ring Ground Over-Current protection				40	mA	$I_{LOOP} = 25mA, V_{BAT} = 48V$
					50	mA	$I_{LOOP} = 30mA, V_{BAT} = 48V$
7	Off-Hook Detect Output Low Voltage (On-hook) Output High Voltage (Off-hook)	$V_{OL}$			0.4	V	Active high logic
		$V_{OH}$	2.7			V	
8	Off-Hook Detect Output Low Current (On-hook) Output High Current. (Off-hook)	$I_{OL}$			8	mA	
		$I_{OH}$			-200	μA	

**DC Electrical Characteristics<sup>†</sup>** - Voltages are with respect to GNDA unless otherwise stated.

	Characteristics	Sym	Min	Typ <sup>‡</sup>	Max	Units	Test Conditions
9	RC, PD Control Input Input Low Volt (no activation)	$V_{IL}$	2.0		0.7	V	Active high logic
	Input High Volt (activation)	$V_{IH}$					LSTTL compatible
10	RC, PD control Input Input Low Current (no activation)	$I_{IL}$			50	$\mu$ A	
	Input high current (activation)	$I_{IH}$					0.5
11	PD Control Input Input Low Current	$I_{IL}$			0.5	mA	
	Input High Current	$I_{IH}$					0.3

<sup>†</sup> DC Electrical Characteristics are over recommended operating supply voltages.

<sup>‡</sup> Typical figures are at 25°C with nominal  $\pm 5V$  supplies and are for design aid only.

**AC Electrical Characteristics**

	Characteristics	Sym	Min	Typ <sup>‡</sup>	Max	Units	Test Conditions
1	Ringling Voltage (rms)	$V_{RING}$	17		90 25	$V_{rms}$ Hz	Superimposed on $V_{BAT} = -48V$
2	Ringer Equivalence Number	REN			3		
3	Ring Trip Detect time			200		ms	Cap = 1uF
4	Input AC Impedance 2-wire	$Z_{in}$		600		$\Omega$	
5	Input Impedance at $V_R$			100		k $\Omega$	
6	Output Impedance at $V_x$			10		$\Omega$	
7	Gain 2-wire to $V_x$		-1.3	-1.0	-0.7	dB	Input 3dBm, 1kHz across Tip and Ring 300-3400 Hz
	Gain relative to Gain @ 1kHz		-0.15		+0.15		
8	Gain $V_R$ to 2-wire		-1.3	-1.0	-0.7	dB	Input 1.0 $V_{rms}$ 1kHz at $V_R$ $Z_{Load} = 600\Omega$ 300 - 3400 Hz
	Gain relative to Gain @ 1kHz		-0.15		+0.15	dB	
9	2-wire Return Loss over 300-3400Hz	RL	20	30		dB	Input 0.5 $V_{rms}$ , 1kHz across Tip and Ring, $Z_{Load} = 600\Omega$
10	Transhybrid Loss	THL	20	30		dB	Input 0.5 $V_{rms}$ , 1kHz at $V_R$ $Z_{Load} = 600\Omega$
11	Longitudinal to Metallic Balance over 300-3400 Hz		50	55		dB	Input 0.5 $V_{rms}$
12	Total Harmonic Distortion at $V_X$	THD		0.1	1.0	%	Input 3dBm, 1 kHz across Tip and Ring,
	at Tip and Ring			0.1	1.0	%	Input 1.0 $V_{rms}$ 1kHz at $V_R$
13	Common Mode Rejection Ratio 2-wire to $V_x$	CMRR	40	50		dB	Input 0.5 $V_{rms}$ , 1kHz
14	Idle channel Noise	$N_c$			14	dBrnC	C @ & $V_X$ Message
15	Power supply rejection ratio	PSRR					1 $V_{PP}$ ripple, 1kHz on $V_{CC}/V_{EE}/V_{BAT}$ , measure at $V_X$ and across Tip & Ring
	$V_{CC}$		26			dB	
	$V_{EE}$		26			dB	
	$V_{BAT}$		26			dB	

<sup>‡</sup> Typical figures are at 25°C with nominal  $\pm 5V$  supplies and are for design aid only.

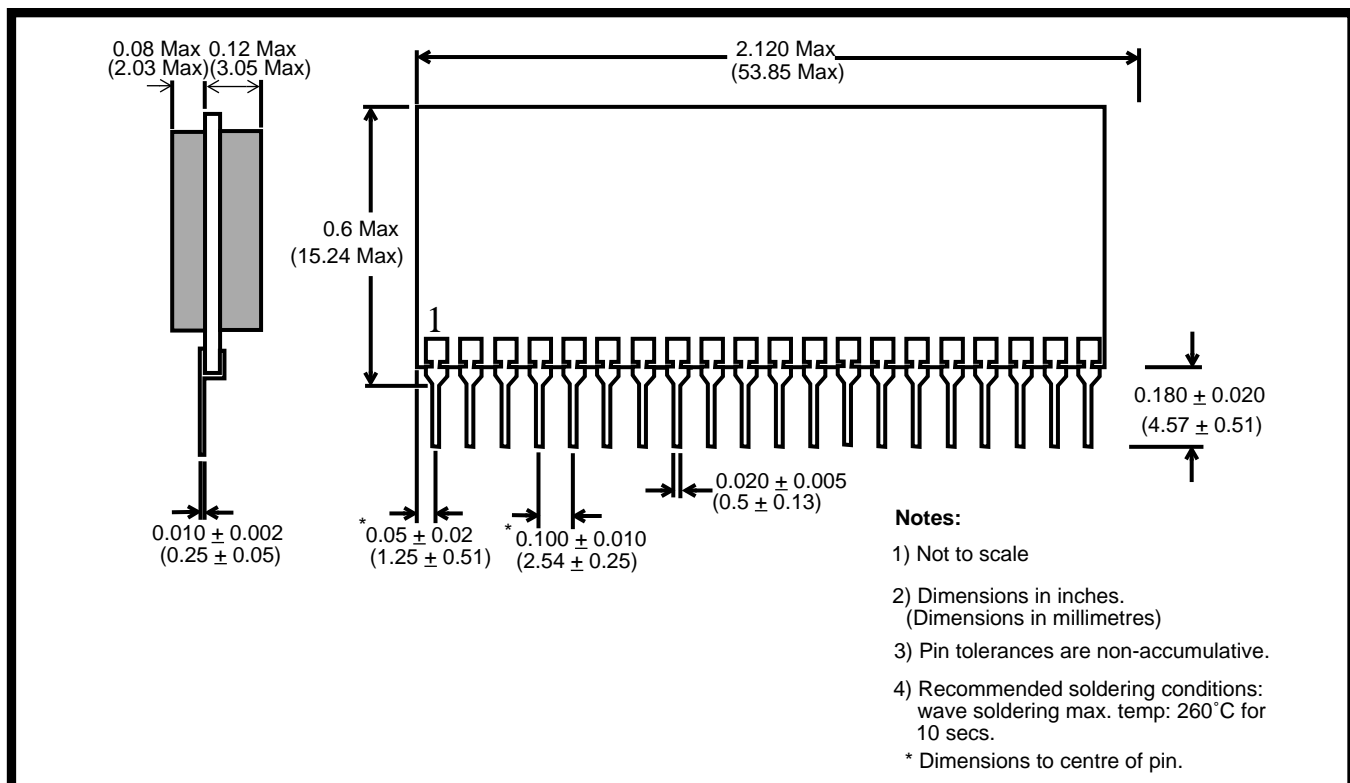

Figure 4 - Mechanical Data

Notes: